

## Oval Tubular Handles

Tube Aluminum, Handle Legs Zinc Die Casting,  
Mounting from the Back

### SPECIFICATION

#### Handle tube

Aluminum

- Powder coated  
Black, RAL 9005, textured finish **SW**  
Handle legs black
- Anodized, natural color **EL**  
Handle legs black
- Anodized, natural color **ES**  
Handle legs silver

#### Handle legs

Zinc die casting

Powder coated, textured finish

- Black, RAL 9005 for SW / EL
- Silver, RAL 9006 for ES

#### Cover

Plastic, light gray



### INFORMATION

Oval tubular handles GN 334 are attractive in design and highly stable.

The handle tube can be mounted without any further machining, allowing special lengths to be realised easily.

### TECHNICAL INFORMATION

- Load Rating Information (see page A35)

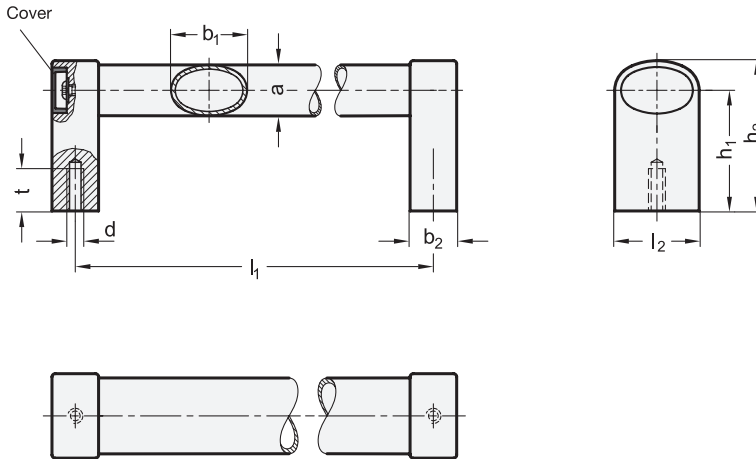

\* Complete with

**SW** **EL** **ES**

### GN 334

Description	b <sub>1</sub>	l <sub>1</sub> ±0.5	a	b <sub>2</sub>	d	h <sub>1</sub>	h <sub>2</sub>	l <sub>2</sub>	t min.	Δ
GN 334-36-200-*	36	200	24	22	M 8	57	71	40	15	480
GN 334-36-250-*	36	250	24	22	M 8	57	71	40	15	522
GN 334-36-300-*	36	300	24	22	M 8	57	71	40	15	560
GN 334-36-350-*	36	350	24	22	M 8	57	71	40	15	620
GN 334-36-400-*	36	400	24	22	M 8	57	71	40	15	660
GN 334-36-500-*	36	500	24	22	M 8	57	71	40	15	720
GN 334-36-600-*	36	600	24	22	M 8	57	71	40	15	840
GN 334-36-800-*	36	800	24	22	M 8	57	71	40	15	940

Weight SW